

2.4 VSAT, 2-way communication via satellite

Design a Ku-band VSAT transmitter or transceiver that meets IESS-308

NXP Ku-band RF PLL TFF1003HN for VSAT

The TFF1003HN is a Ku-band RF PLL intended for low phase-noise Local Oscillator (LO) circuits in Ku-band VSAT transmitters and transceivers. Manufactured in a high-performance SiGeC process, it delivers extremely low phase noise at 13.05 GHz from a 10-MHz reference, and complies with the IESS-308 from Intelsat.



Features

- Phase noise compliant with IESS-308 (Intelsat)
- LO generator with VCO range from 12.8 to 13.05 GHz
- Input signal from 50 to 815 MHz
- Differential input and output
- Divider settings at 16, 32, 64, 128 or 256
- Lock-detect output
- SiGeC technology (120-GHz f_T process)
- HVQFN24 (SOT616-1) package

Applications

- VSAT up-converters
- Local oscillator signal generation

VSAT networks are commonly used to transmit narrowband data, such as point-of-sale transactions for credit cards, or to transmit broadband data that supports satellite Internet access to a remote location, VoIP, or video.

The network typically consists of a dish antenna, an outdoor unit, and an indoor unit. The outdoor unit is used for frequency translation between RF and IF, and usually includes a microwave-based uplink/downlink separator, a Low Noise Block (LNB) for receiving the downlink signals, and a Block Up Converter (BUC).

The TFF1003HN can be used to create the LO generator for a linear BUC (meaning the IF or RF conversion is done by mixing with an LO). In Ku-band applications, the LO frequency is either 13.05 GHz for standard range or 12.8 GHz for extended range.

To enable precise frequency and time multiplexing, the downlink signal provides an accurate frequency reference of 10 MHz. The indoor unit frequency multiplexes this with the uplink IF signal, and the LO signal in the BUC needs to be frequency locked to the reference.

The TFF300HN is housed in a 24-pin HVQFN (SOT616-1) package. The pins have been assigned for optimal performance. Three voltage domains are used to separate the block on the IC, and two pins for each output (OUT-P) and (OUT-N) have been reserved to match a typical layout using a linewidth of $Z=50\ \Omega$ microstrip on a 20-mil RO4003 board (1.1 mm).

The ground pins have been placed next to the reference input and the output, and, to minimize crossings in the application, all the supply pins are on the same side of the IC.

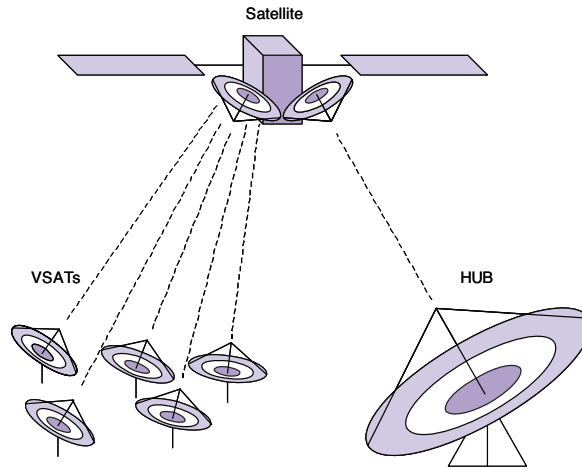

Typical VSAT network

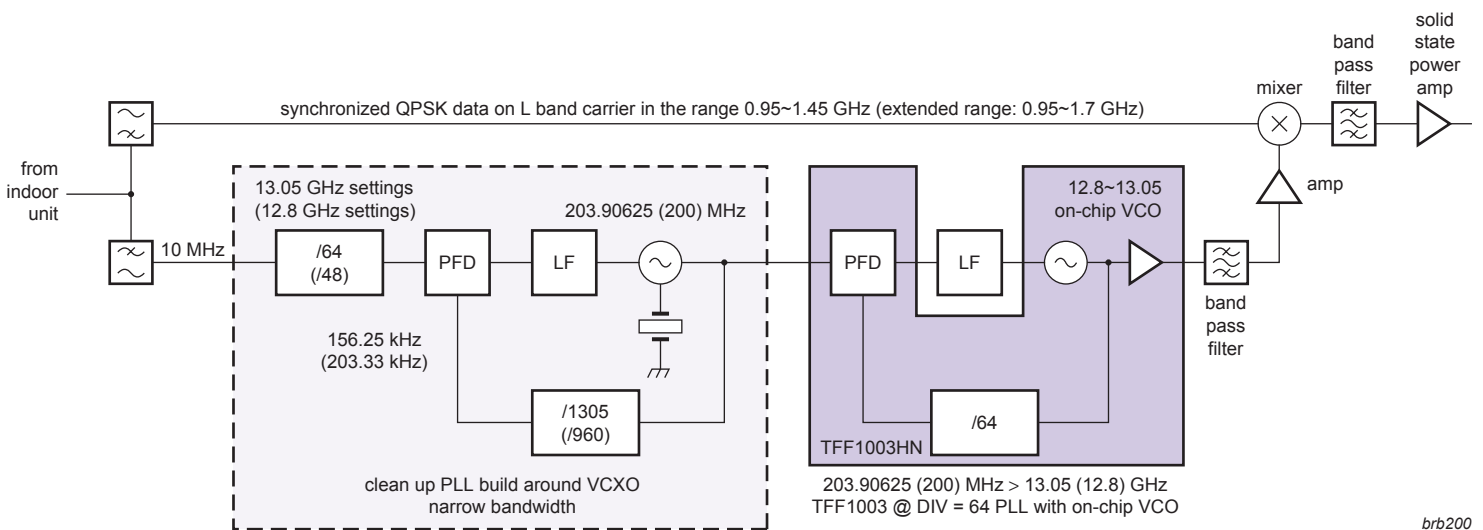

brb200

Complete LO generator for linear BUC with TFF1003HN

Type	Input frequency range (MHz)	Supply voltage (V)	Supply current (mA)	Phase noise (dBc/Hz)	Spurious noise (dBc)	Output power (dBm)
TFF1003HN *	50 to 815	3.0 to 3.6	200	-138 with 10-MHz reference signal	-70	-7 to -3

* As designed into complete BUC LO generator